



DESCRIPTION:

- Stadium shaped towel ring
- Available in a chrome finish
- Solid brass construction
- Corrosion & discolouration resistant
- Complies with CSA & IAPMO standards

SHIPPING INFORMATION:

- Length: 9.5" / 241mm
- Net Weight: 0.8 kg / 1.76 lbs.
- Width: 6" / 152mm
- Gross Weight: 1 kg / 2.2 lbs.
- Height: 3" / 76mm

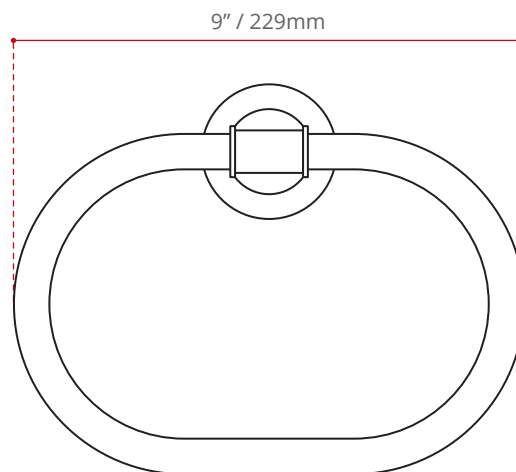
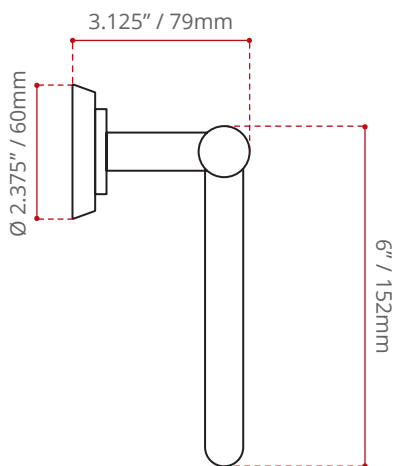

DISCLAIMER:
Measurements may vary $\pm \frac{1}{4}$ "
(Diagram Not to scale)

